



Air Filtration

CLEARPOINT®

energy saving compressed air filtration

Truth in Compressed Air.



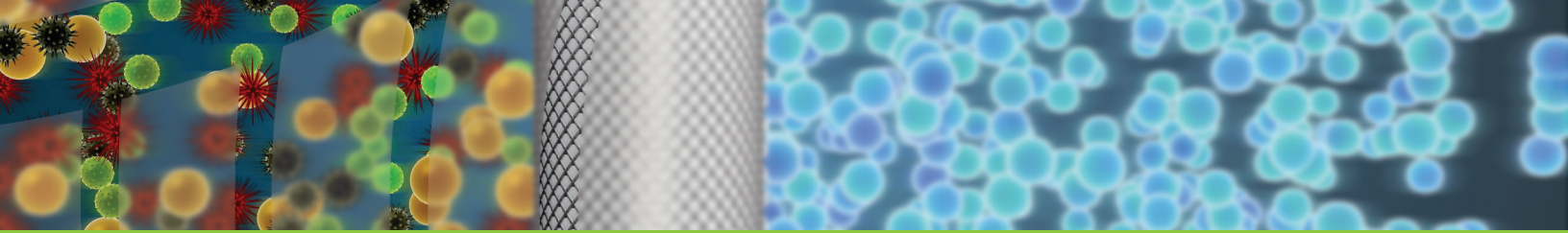

CLEARPOINT® Filters

At a Glance

During compressed air generation and distribution, contaminants are introduced to the air stream at various stages of the compressed air network. Compressed air filters, which come in various grades, remove these contaminants, as well as humidity and oil from the compressed air stream. This is a critical step as these can lead to a deterioration in quality, machine failure, or even to a loss of production or to products that must be disposed of.

Features and Benefits

+ Energy Efficient by Design

Ultra-low differential pressure across the range with advanced eco series pleated elements

+ Flow Optimized Housing

Unique curved inlet design was engineered for the lowest possible differential pressure

+ Maximum Reliability

Double threaded filter head, extruded, fully anodized, and zero air loss drain option

+ Performance

Superior retention rate up to 99.999%

+ Simplified Maintenance

Simple, push-fit element designs without tie-rods — we considered the details in the design

How it Works

1 Compressed Air Inlet

The compressed air enters the inlet of the CLEARPOINT® filter housing, which have all been designed to compliment the connections of the different compressor manufacturers making port-matching easier during installation.

2 Curved Inlet

Up to 75% less flow resistance is achieved through a unique curved inlet design as the compressed air flows into the physical medium of the filter element.

3 Filtration Process

The untreated compressed air that is laden with liquid oil, oil aerosols, dirt, scale, and other debris and particulate matter now passes through an innovative, high bed depth filter material designed so the maximum amount of particles are desposited in the material with maximum retention. The exterior of the soft pleat medium is an open cell, synthetic support mesh to ensure the required rigidity for the various filter systems without sacrificing any filter surface area.

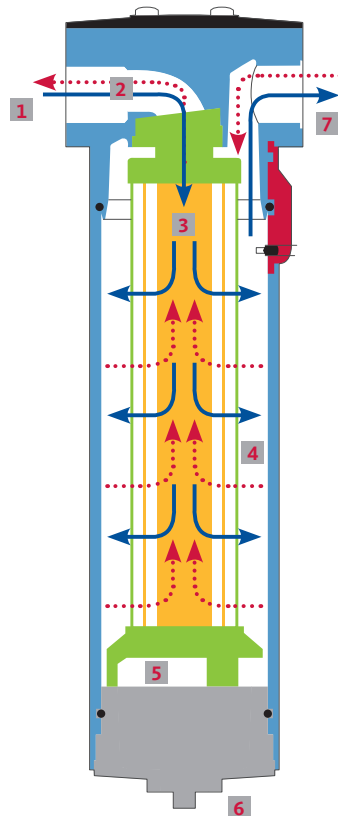

4 Treated Compressed Air

The compressed air has now passed all the way through the filter medium and is considered as treated.

5 Condensate Collection Zone

A large condensate collection zone at the base of the housing coupled with the unique legs of the filter end cap create a generous void to prevent the entrainment of already separated condensate.

6 Condensate Removal

Any condensate present in the filter housing is drained either by a float drain or zero air loss BEKOMAT®. A hexagonal profile has also been included at the base of the filter housing allowing it to be easily opened for element changes and maintenance.

7 Compressed Air Outlet

The fully treated compressed air that is now free of fluids, solids, and other pollutants flows downstream to other inline components or the point-of-use.

Coalescing filtration flow (inside / out)

Particulate filtration flow (outside / in)

CLEARPOINT® Filters

Compare



Threaded Series

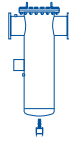

Flanged Series



Activated Carbon Series



PN50 High Pressure Series



HP High Pressure Series



H In-line Heater Series

Flow Rates

25 - 1,900 scfm

1,900 - 21,000 scfm

80 - 330 scfm

100 - 2,750 scfm

25 - 2,000 scfm

30 - 60 scfm

Maximum Operating Pressure

232 psig

200 psig

232 psig

725 psig

1,450 - 7,250 psig

232 psig

Standard Pipe Connection Sizes

3/8" - 3" NPT

4" - 12" Flange

1/2" - 1 1/2" NPT

3/8" - 2" NPT

3/8" - 2" NPT

3/8" - 2" NPT

Housing Material

Anodized, powder coated aluminum

Powder coated carbon steel

Anodized, powder coated aluminum

Anodized, powder coated aluminum

Stainless steel

Anodized, powder coated aluminum

Available Options

Zero air loss drain, Differential pressure gauge, Cover3More extended warranty

Cover3More extended warranty

Oil check indicator, Manual valve, Cover3More extended warranty

Drain connection kit, Zero air loss drain, Differential pressure gauge, Cover3More extended warranty

Manual valve, Differential pressure gauge, Cover3More extended warranty

Available for 115 or 230 VAC operation, Cover3More extended warranty

Product Family



Flanged and threaded filters



High pressure (PN) filter



High pressure (HP) filter

Technical Details

CLEARPOINT® Threaded Coalescing and Particulate Filters

with float drain or BEKOMAT® and with or without differential pressure gauge and new eco series elements

- › Advanced CLEARPOINT® eco series elements
- › Validated in accordance with ISO 12500-1 and 3
- › CRN approved
- › Filter for natural gas (CNG) on request
- › Max. operating pressure: 232 psig
- › Max. operating temperature: 140 °F

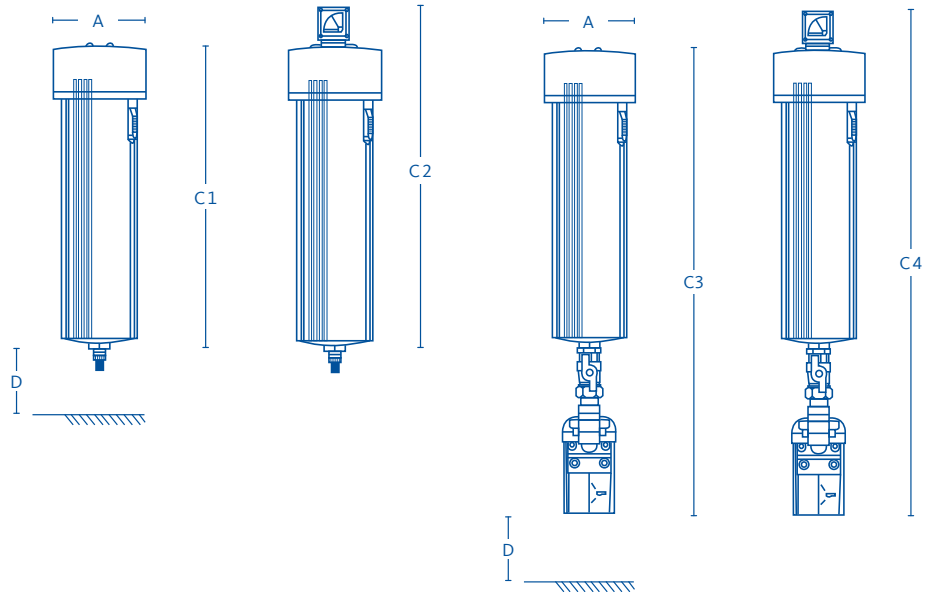

CLEARPOINT®	S040	S045	S050	S055	S075	S100	M010	M012	M015
Pipe size (NPT)	3/8"	1/2"	1/2"	1/2"	3/4"	1"	1"	1"	1 1/2"
Flow rate (scfm)	25	30	50	80	100	125	160	200	250
Element Size	04*	04*	05*	06*	07*	07*	10*	12*	15*
Dimension data									
A (inches)	2.95	2.95	2.95	2.95	3.94	3.94	3.94	3.94	5.75
C1 (inches)	7.09	7.09	8.27	10.43	11.02	11.02	13.78	15.16	14.17
C2 (inches)	9.65	9.65	10.83	12.99	13.58	13.58	16.34	17.72	16.73
C3 (inches)	15.55	15.55	16.73	18.90	19.49	19.49	22.24	23.62	22.83
C4 (inches)	18.11	18.11	19.29	21.46	22.05	22.05	24.80	26.18	25.39
D (inches)	5.91	5.91	5.91	5.91	5.91	5.91	5.91	5.91	6.30
Weight (lbs)	1.65	1.65	1.87	2.65	3.75	4.18	4.63	4.85	9.04

CLEARPOINT®	M018	M019	M020	M022	M023	M025	M027	M030	M032
Pipe size (NPT)	1 1/2"	1 1/2"	2"	2"	2"	2 1/2"	2 1/2"	3"	3"
Flow rate (scfm)	330	450	500	600	800	1000	1300	1500	1900
Element Size	18*	20*	20*	22*	23*	25*	27*	30*	32*
Dimension data									
A (inches)	5.75	5.75	5.75	5.75	5.75	10.24	10.24	10.24	10.24
C1 (inches)	16.46	18.43	18.43	22.24	26.89	26.42	30.51	35.24	41.14
C2 (inches)	19.02	20.99	20.99	24.80	29.45	29.98	33.07	37.80	43.70
C3 (inches)	24.92	26.89	26.89	30.71	35.35	34.88	38.98	39.76	49.61
C4 (inches)	27.48	29.45	29.45	33.27	37.91	37.44	41.54	42.32	52.17
D (inches)	6.30	6.30	6.30	6.30	6.30	7.87	7.87	7.87	7.87
Weight (lbs)	9.92	10.61	11.24	13.45	15.65	43.87	49.82	57.10	65.92

* ELEMENT GRADE	ELEMENT TYPE	MICRON RATING	OIL CARRYOVER	DRY Δ PRESSURE (psid)	WET Δ PRESSURE (psid)
Grade CX	Coarse	25 μm	5 mg/m ³	.44	.73
Grade FX	Fine	1 μm	.1 mg/m ³	.73	2.17
Grade SX	Superfine	.01 μm	.01 mg/m ³	.87	2.90
Grade A	Activated Carbon Element	.01 μm	.003 mg/m ³	-	1.02

Correction Factor

Operating Pressure (psig)	20	40	60	80	90	100	110	120	130	140	160	180	200	230
Correction Factor	.30	.48	.65	.82	.91	1.00	1.09	1.17	1.26	1.35	1.52	1.70	1.87	2.13

Technical Details

CLEARPOINT® Flange Coalescing and Particulate Filters with BEKOMAT® and connection kit with differential pressure gauge

- › Advanced CLEARPOINT® eco series elements
- › Validated in accordance with ISO 12500
- › Designed according to ASME Sec. VII, Div. 1
- › UM stamp standard and CRN optional
- › Max. operating pressure: 232 psig
- › Max. operating temperature: 140 °F

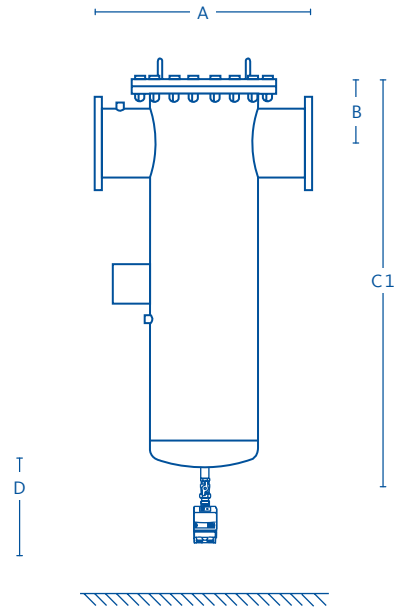

CLEARPOINT®	L100	L102	L150	L156	L200	L204	L254	L304
Pipe size (ANSI)	4"	4"	6"	6"	8"	8"	10"	12"
Flow rate (scfm)	1900	2800	3800	6500	7500	9300	13000	21000
Element Size	88*							
Dimension data								
A (inches)	21.25	21.25	23.50	23.75	28.00	30.31	34.65	38.98
B (inches)	6.88	7.13	8.00	8.25	9.50	9.75	9.88	10.87
C1 (inches)	46.50	47.38	46.88	50.38	53.00	56.34	60.18	64.26
D (inches)	13.00	18.00	18.00	18.00	18.00	18.00	18.00	18.00
Weight (lbs)	195	266	283	328	534	623	727	825

* ELEMENT GRADE	ELEMENT TYPE	MICRON RATING	OIL CARRYOVER	OIL VAPOR	DRY Δ PRESSURE (psid)	WET Δ PRESSURE (psid)	APPROVALS
Grade CX	Coarse	25 µm	5 mg/m ³	-	.44	.73	ASME Coded Vessel with "UM" Stamp as standard (CRN Optional)
Grade FX	Fine	1 µm	.1 mg/m ³	-	.73	2.17	
Grade SX	Superfine	.01 µm	.01 mg/m ³	-	.87	2.9	
Grade A	Activated Carbon	.01 µm	-	.003 mg/m ³	1.45	-	

Correction Factor

Operating Pressure (psig)	20	40	60	80	90	100	110	120	130	140	160	180	200
Correction Factor	.30	.48	.65	.82	.91	1.00	1.09	1.17	1.26	1.35	1.52	1.70	1.87

■ Technical Details

CLEARPOINT® Threaded Activated Carbon Cartridge Filters

with manual ball valve

- › With activated carbon filter cartridge
- › Removal of solid particles up to 1 µm
- › Residual oil vapor content down to .003 mg/m³
- › CRN approved
- › Max. inlet moisture: 30% (dryer required upstream)
- › Max. operating pressure: 232 psig
- › Max. operating temperature: 140 °F

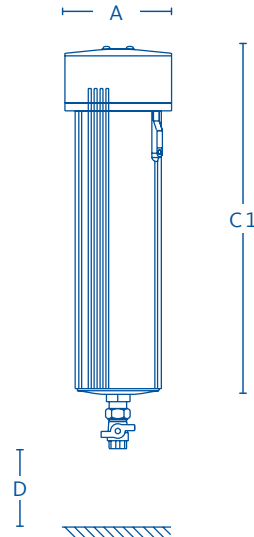

CLEARPOINT®	S055	M010	M018
Pipe size (NPT)	½"	¾"	1 ½"
Flow rate (scfm)	80	160	330
Element Size	06V	10V	18V
Dimension data			
A (inches)	2.95	3.94	5.75
C1 (inches)	10.43	13.78	16.46
D (inches)	5.91	5.91	6.30
Weight (lbs)	2.65	4.63	9.92

ELEMENT GRADE	ELEMENT TYPE	MICRON RATING	OIL CARRYOVER	Δ PRESSURE (psid)
Grade V	Activated Carbon Cartridge	1 µm	.003 mg/m ³	.54

Correction Factor

Operating Pressure (psig)	20	40	60	80	90	100	110	120	130	140	160	180	200	230
Correction Factor	.30	.48	.65	.82	.91	1.00	1.09	1.17	1.26	1.35	1.52	1.70	1.87	2.13

Technical Details

CLEARPOINT® PN50 Threaded Coalescing and Particulate High Pressure Filters

with open port or BEKOMAT® connection kit (drain sold separately) without pressure gauge

- › Advanced CLEARPOINT® eco series elements
- › Validated in accordance with ISO 12500-1 and 3
- › Max. operating temperature: 140 °F
- › Max. operating pressure: 725 psig

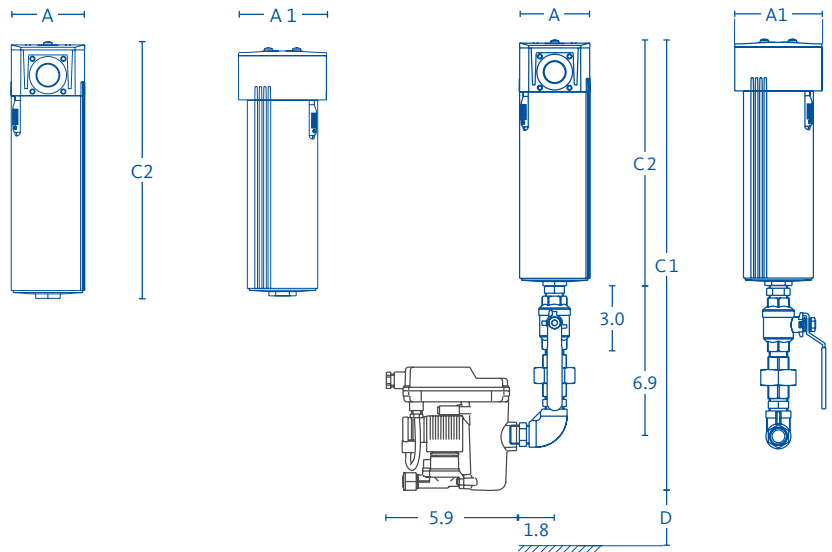

CLEARPOINT® PN50	HP50S040	HP50S050	HP50S055	HP50S075	HP50M010	HP50M012	HP50M015	HP50M018	HP50M020	HP50M022	HP50M023
Pipe size	3/8"	1/2"	1/2"	3/4"	1"	1"	1 1/2"	1 1/2"	2"	2"	2"
Flow rate (scfm)	100	190	300	440	600	710	1000	1210	1720	2065	2750
Element Size	04*	05*	06*	07*	10*	12*	15*	18*	20*	22*	23*
Dimension data											
A (inches)	2.95	2.95	2.95	3.95	3.95	3.95	5.75	5.75	5.75	5.75	5.75
A1 (inches)	2.36	2.36	2.36	3.15	3.15	3.15	4.72	4.72	4.72	4.72	4.72
C1 (inches)	16.50	16.50	19.90	20.50	23.20	24.60	23.80	25.90	27.80	31.60	36.30
C2 (inches)	7.10	8.30	10.40	11.00	13.80	15.20	14.40	16.50	18.40	22.20	26.90
D (inches)	7.10	7.10	7.10	7.10	7.10	7.10	7.10	7.10	7.10	7.10	7.10
Weight (lbs)	1.65	1.85	2.65	3.75	4.63	4.85	9.04	9.92	11.24	13.45	15.65

* ELEMENT GRADE	ELEMENT TYPE	MICRON RATING	OIL CARRYOVER	OIL VAPOR	DRY Δ PRESSURE (psid)
Grade CX	Coarse	25 µm	5 mg/m ³		.54
Grade FX	Fine	1 µm	.1 mg/m ³		.86
Grade SX	Superfine	.01 µm	.01 mg/m ³		1.04
Grade A	Activated Carbon	.01 µm	-	.003 mg/m ³	.70

Correction Factor

Operating Pressure (psig)	60	90	100	150	200	300	450	600	725
Correction Factor	.14	.18	.24	.35	.43	.59	.73	.88	1.00

Technical Details

CLEARPOINT® HP High Pressure Filters

with open port without pressure gauge up to 7,250 psig

- › Stainless steel housing
- › Max. operating temperature: 140 °F (HP350S075 and HP350M010 only)
- › Max. operating temperature: 248 °F (all other models)
- › Max. inlet pressure: 1,450 - 7,250 psig

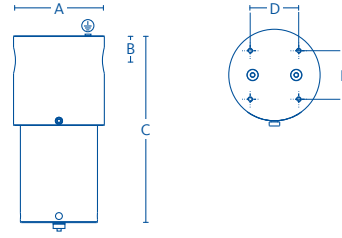

CLEARPOINT® HP 100	HP100S040	HP100S045	HP100S050	HP100S055	HP100S075	HP100M010	HP100M015	HP100M020
Max. Operating Pressure (psig)	1,450	1,450	1,450	1,450	1,450	1,450	1,450	1,450
Pipe size (NPT)	3/8"	3/8"	1/2"	1/2"	3/4"	1"	1 1/2"	2"
Flow rate (scfm)	25	60	160	270	400	700	1000	2000

Dimension data								
A (inches)	2.36	3.11	3.07	3.07	4.49	4.49	6.85	6.85
B (inches)	.65	.81	.91	.91	1.16	1.16	1.97	1.97
C (inches)	4.61	5.51	8.43	10.39	10.63	16.54	18.94	30.87
D (inches)	.98	1.39	1.57	1.57	2.36	2.36	3.94	3.94
Weight (lbs)	4.41	9.92	8.82	12.13	23.15	30.20	74.96	92.60

CLEARPOINT® HP 350	HP350S030	HP350S040	HP350S045	HP350S050	HP350S075	HP350M010	HP350M012	HP350M015
Max. Operating Pressure (psig)	5,075	5,075	5,075	5,075	5,075	5,075	5,075	5,075
Pipe size (NPT)	1/4"	3/8"	3/8"	1/2"	3/4"	1"	1"	1 1/2"
Flow rate (scfm)	30	75	205	350	520	920	1300	2600

Dimension data								
A (inches)	2.36	3.11	3.46	3.46	5.47	5.47	6.65	6.65
B (inches)	.65	.81	.91	.91	1.47	1.47	1.94	1.94
C (inches)	4.61	5.51	8.43	10.39	11.26	17.17	18.90	30.83
D (inches)	.98	1.39	1.57	1.57	3.15	3.15	3.15	3.15
Weight (lbs)	4.41	9.92	14.33	16.53	45.19	59.52	99.23	156.53

CLEARPOINT® HP 500	HP500S030		HP500S040		HP500S045		HP500S050	
Max. Operating Pressure (psig)	7,250		7,250		7,250		7,250	
Pipe size (NPT)	1/4"		3/8"		3/8"		1/2"	
Flow rate (scfm)	30		80		220		380	

Dimension data								
A (inches)	2.36		3.11		4.45		4.45	
B (inches)	.65		.81		.98		.98	
C (inches)	4.61		5.51		8.70		10.67	
D (inches)	.98		1.39		2.36		2.36	
Weight (lbs)	4.41		9.92		26.46		28.66	

ELEMENT GRADE	ELEMENT TYPE	MICRON RATING	OIL CARRYOVER	OIL VAPOR	DRY Δ PRESSURE (psid)
Grade CX	Coarse	25 μm	5 mg/m ³	-	.54
Grade FX	Fine	1 μm	.1 mg/m ³	-	.86
Grade SX	Superfine	.01 μm	.01 mg/m ³	-	1.04
Grade A	Activated Carbon	.01 μm	-	.003 mg/m ³	.70

Correction Factor

Operating Pressure (1,450 psig)	300	450	600	725	900	1,100	1,200	1,300	1,450
Correction Factor	.45	.56	.64	.71	.78	.84	.90	.95	1.00

Operating Pressure (5,075 psig)	3,000		3,600		4,500		5,075	
Correction Factor	.84		.89		.94		1.00	

Operating Pressure (7,250 psig)	4,500		5,000		5,800		6,500		7,250	
Correction Factor	.89		.93		.96		.98		1.00	

■ Technical Details

CLEARPOINT® H Compressed Air Heaters

with adjustable temperature control

- › For the adjustable heating of compressed air
- › Adjustable temperature from 86 °F to 140 °F
- › Ready for connection with a three-prong plug
- › Encapsulated corrosion-free stainless-steel heating cartridges
- › Available touch protection option
- › Optional 250 VAC / 50 Hz power supply available
- › Max. operating pressure: 232 psig

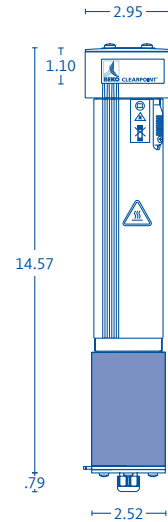

CLEARPOINT® H	S040	S050
Pipe size (NPT)	3/8"	1/2"
Max. volume flow at 100 psig	30 scfm	60 scfm
Setting range compressed-air outlet temperature (°F)*	+86 °F - +140 °F	+86 °F - +140 °F
Max. perm. operating overpressure (psig)	232	232
Pressure difference	< 2.18 psig	< 2.9 psig
Voltage**	115 VAC / 60 Hz +/-10%	115 VAC / 60 Hz +/-10%
Inlet temperature (°F)	+36 °F - +122 °F	+36 °F - +122 °F
Ambient temperature (°F)	+36 °F - +122 °F	+36 °F - +122 °F
Internal safety switch-off temperature (°F)	+183 °F	+183 °F
Max. housing temperature (°F)	+176 °F	+176 °F
Max. compressed-air outlet temperature (°F)*	+140 °F	+140 °F
Power (W)***	420 (750)	420 (750)
Volume (l)	0.42	0.42
Weight (lbs)	5.3	5.3
Protection class	IP 54	IP 54

* Depending on volume flow

** Other voltages on request

*** At +68 °F: making current max. 4 A, making capacity max. 750 W



+3
Years on all
Products

ask your
**sales
representative**
for complete details
and extend your full
warranty today

Cover3More Extended Warranty Program

We give you more: In addition to a robust, standard 2-year warranty on BEKO Technologies products, we offer our customers the option of extending the standard warranty even further with the **Cover3More** program – a low cost, all-encompassing, and simple warranty extension program.

- › Extends the standard factory warranty for an additional 3-years
- › May be purchased at any time up to 18-months post-sale
- › Can be applied to stocked or installed products
- › No hassle and easy to calculate without any hidden costs

Secure your future with a minimal investment. The **Cover3More** extended warranty program from BEKO Technologies ensures that your investment is covered for a total of 5-years at a nominal cost.

- › Applicable to all product lines
- › 2-year standard warranty covers parts and labor
- › 3-year extended warranty covers parts only, no parts restrictions
- › Significantly reduces your risk of having unexpected costs

Cover3More on the Following Product Lines

DRYPOINT® RA	Refrigerant Air Dryers	BEKOMAT®	Zero Air Loss Drains
DRYPOINT® X / AC	Desiccant Air Dryers	QWIK-PURE®/ÖWAMAT®	Oil-water Separators
DRYPOINT® M	Membrane Air Dryers	METPOINT®	Instrumentation
CLEARPOINT®	Filters and Water Separators	BEKOKAT®	Hydrocarbon Removal Systems

Reliability you can count on: With the Cover3More extended warranty program, BEKO Technologies not only lengthens the standard warranty period by 3-years from the installation date, but also draws on the company's vast compressed air industry experience to quickly resolve any product problems you may experience in the least disruptive way possible, thereby keeping downtime to an absolute minimum. Should a repair be required, it will be handled by qualified, authorized personnel, and only original parts will be used.

All maintenance procedures, including filter element changes, must be carried out in accordance with the manual in order to maintain any warranty.

Cover3More Extended Warranty Program

Compare

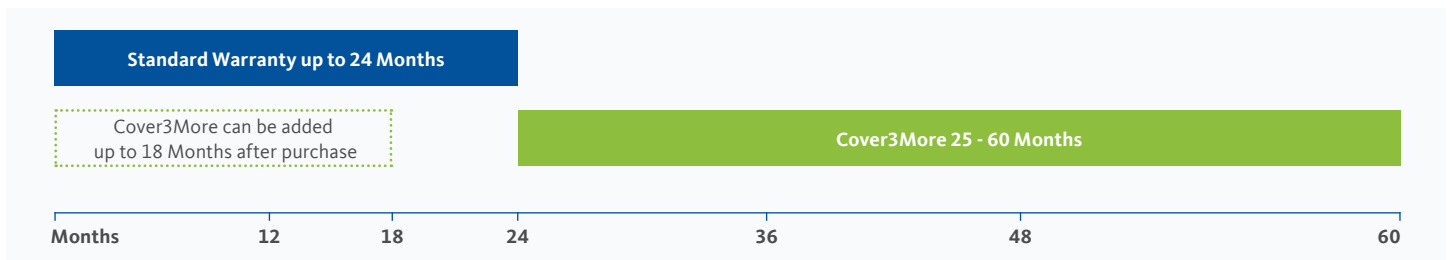

How it Works

- 1 Select the product or products that you wish to cover with the extended warranty.
- 2 Contact your BEKO Technologies sales representative to help calculate your final net price for extended coverage.
- 3 Include the information received along with your purchase order or purchase the warranty extension up to 18-months post-sale.

What we need from you: It's not much. In fact, if you are purchasing the Cover3More extended warranty with a new equipment purchase, all you have to do is include a line item on your order indicating which items you wish you cover, and we will take care of the rest. If you happen to be adding coverage to a product you've already taken delivery of, then all we need is the company name and contact information of the original purchaser, the product model number of the product to be covered, serial number, and original purchase order number or BEKO Technologies invoice number, and we will apply coverage appropriately. **Please feel free to contact us at +1 (800) 235-6797 to get started.**

What's in the fine print: The optional 36-month warranty extension (i.e. Cover3More) is a limited extended warranty that covers parts only from months 25-60.

However, all of the aforementioned installation, performance, and quality requirements must still be met in order to maintain extended warranty coverage. Failure to do so will render all warranties null and void.

The limited extended warranty coverage may be purchased and applied to any of the BEKO Technologies product lines included in the scope of the Cover3More extended warranty program from the original date of purchase from BEKO Technologies to 18-months thereafter.

Extended warranty coverage may not be purchased during the final 6-months of the standard warranty coverage, which are months 19-24 from the date of shipment or at BEKO Technologies' discretion, the date of installation.

The purchase price of the Cover3More limited extended warranty is not prorated and the current published purchase price is always applied.

Should the extended warranty coverage be purchased post-delivery or post-sale, then the serial number of all products to which the warranty shall be extended must be provided to BEKO Technologies at the time of purchase of the extended warranty.

Reliable | Efficient | Innovative

What can we do for you?



BEKO TECHNOLOGIES CORP.
900 Great Southwest Pkwy SW
Atlanta, GA 30336
USA
Phone +1 (404) 924-6900
Fax +1 (404) 629-6666
www.bekousa.com

